

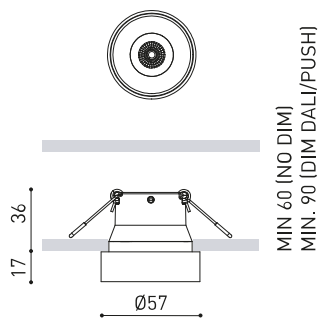

## GRÖÖE



Name	SHOT LIGHT S SEMI RECESSED SPOT DIM PUSH 4000K WT
Artikelnummer	A4950302WT
Farbe	Weiß strukturiert
RAL	9016
Kategorie	CEILING RECESSED

Typ	LED
Bruttolichtstrom	720 lm
Farbtemperatur	4000 K
Farbstabilität	MacAdam Step 2
Farbwiedergabeindex	CRI > 90
Leistung	6 W
Stromstärke	500 mA
Lichtausbeute	120 lm/W
Nutzlebensdauer der LED in Betriebsstunden	L80B10 > 60.000h

## LICHTQUELLE

Typ	LED
Bruttolichtstrom	720 lm
Farbtemperatur	4000 K
Farbstabilität	MacAdam Step 2
Farbwiedergabeindex	CRI > 90
Leistung	6 W
Stromstärke	500 mA
Lichtausbeute	120 lm/W
Nutzlebensdauer der LED in Betriebsstunden	L80B10 > 60.000h

Leuchtenwirkungsgrad (LOR)	89%
Abstrahlwinkel	18°

## LEUCHE | PHOTOMETRISCHE DATEN

Leuchtenwirkungsgrad (LOR)	89%
Abstrahlwinkel	18°

Driver	Inklusiv - Angeschlossen
Leistungswerte des Systems	8,01 W
Spannung	220V/240V
Frequenz	50/60 Hz
Helligkeitssteuerung	Push - Andere DIM, Bitte anfragen
Schutzklasse	<input type="checkbox"/>

## LEUCHE | ELEKTRISCHE DATEN

Driver	Inklusiv - Angeschlossen
Leistungswerte des Systems	8,01 W
Spannung	220V/240V
Frequenz	50/60 Hz
Helligkeitssteuerung	Push - Andere DIM, Bitte anfragen
Schutzklasse	<input type="checkbox"/>

Dichtigkeit	IP20
Wireless control	Bitte anfragen
Notstromaggregat	Bitte anfragen
Einbaumaße	Ø50 mm
Gewicht	160 g
Gewicht inkl. Verpackung	225 g
Abmessungen der Verpackung	208 x 102 x 74 mm
Stück pro Verpackung	1
Materialien	Aluminium / Acrylnitril-Butadien-Styrol / Polycarbonat

## ANDERE DATEN

Dichtigkeit	IP20
Wireless control	Bitte anfragen
Notstromaggregat	Bitte anfragen
Einbaumaße	Ø50 mm
Gewicht	160 g
Gewicht inkl. Verpackung	225 g
Abmessungen der Verpackung	208 x 102 x 74 mm
Stück pro Verpackung	1
Materialien	Aluminium / Acrylnitril-Butadien-Styrol / Polycarbonat



Das Besondere der neuen Version von Shot Light S Semi Recessed ist ihre exquisite Präsenz. Ihr Rahmen ist in verschiedenen Ausführungen erhältlich und verschönert den Raum wie ein Schmuckstück, ohne sich in den Vordergrund zu drängen.

POLAR-KOORDINATEN DIAGRAMM



KEGELDIAGRAMM



UGR

Glare Evaluation According to UGR												
p Ceiling		70	70	50	50	30	70	70	50	50	30	30
p Walls		50	30	50	30	30	50	30	50	30	30	30
p Floor		20	20	20	20	20	20	20	20	20	20	20
Room Size X Y		Viewing direction at right angles to lamp axis					Viewing direction parallel to lamp axis					
2H	2H	-9.4	-8.8	-9.2	-8.6	-8.4	-11.3	-10.7	-11.1	-10.5	-10.3	
	3H	-7.3	-6.7	-7.0	-6.5	-6.3	-6.9	-6.3	-6.6	-6.1	-5.8	
	4H	-4.0	-3.4	-3.7	-3.2	-2.9	-4.6	-4.0	-4.3	-3.8	-3.5	
	6H	-1.8	-1.3	-1.5	-1.0	-0.7	-3.3	-2.8	-3.0	-2.6	-2.3	
	8H	-0.7	-0.2	-0.3	0.1	0.4	-0.6	-0.1	-0.2	0.2	0.5	
4H	12H	0.9	1.4	1.3	1.7	2.0	0.9	1.3	1.2	1.6	1.9	
	2H	-8.9	-8.3	-8.6	-8.1	-7.8	-10.3	-9.7	-10.0	-9.5	-9.2	
	3H	-6.0	-5.5	-5.6	-5.2	-4.9	-5.8	-5.3	-5.5	-5.0	-4.7	
	4H	-2.0	-1.6	-1.6	-1.3	-0.9	-3.1	-2.7	-2.7	-2.4	-2.0	
	6H	0.1	0.4	0.5	0.8	1.2	-1.7	-1.4	-1.3	-1.0	-0.7	
8H	8H	1.3	1.6	1.7	1.9	2.3	1.1	1.4	1.5	1.8	2.2	
	12H	2.9	3.2	3.4	3.6	4.0	2.7	2.9	3.1	3.3	3.8	
	4H	-1.4	-1.1	-1.0	-0.8	-0.4	-2.2	-2.0	-1.8	-1.6	-1.2	
	6H	0.9	1.1	1.3	1.5	1.9	-0.5	-0.2	-0.0	0.2	0.6	
	8H	2.4	2.6	2.9	3.0	3.5	2.4	2.5	2.8	3.0	3.4	
12H	12H	4.3	4.5	4.8	4.9	5.4	4.2	4.3	4.7	4.8	5.3	
	4H	-1.3	-1.0	-0.8	-0.6	-0.2	-2.0	-1.8	-1.6	-1.4	-1.0	
	6H	1.2	1.4	1.7	1.8	2.3	0.1	0.2	0.5	0.7	1.1	
8H	2.9	3.0	3.4	3.5	4.0	2.9	3.0	3.4	3.5	4.0		
Variation of the observer position for the luminaire distances S												
S = 1.0H		+1.9 / -0.6					+1.9 / -0.5					
S = 1.5H		+3.6 / -0.9					+3.7 / -1.1					
S = 2.0H		+5.2 / -1.5					+5.5 / -1.5					
Standard table Correction Summand		---					---					
Corrected Glare Indices referring to 720lm Total Luminous Flux												



Fuente de luz (LED) reemplazable por un profesional autorizado

Replaceable (LED only) light source by an authorized professional.

Source lumineuse (LED) remplaçable par un professionnel agréé

Sorgente luminosa (LED) sostituibile da parte di un professionista autorizzato

Austauschbare (LED) Lichtquelle durch einen autorisierten Fachmann



Equipo de control reemplazable por un profesional autorizado

Replaceable control gear by an authorized professional

Dispositif de commande remplaçable par un professionnel agréé

Alimentatore sostituibile da parte di un professionista autorizzato

Auswechselbares Betriebsgerät durch autorisierten Fachmann

INSTRUCCIONES PARA EL FINAL DE VIDA Y LA ELIMINACIÓN LOS COMPONENTES  
 INSTRUCTIONS ON END-OF-LIFE AND COMPONENT DISPOSAL  
 INSTRUCTIONS POUR LA GESTION DES COMPOSANTS EN FIN DE VIE ET LEUR MISE AU REBUT  
 ISTRUZIONI PER IL FINE VITA E LO SMALTIMENTO DEI COMPONENTI  
 ANWEISUNGEN ZUR ENTSORGUNG DER LEUCHTENKOMPONENTEN



Interrumpir la alimentación del aparato  
 Cut the power supply to the luminaire  
 Couper l'alimentation du luminaire  
 Interrompere l'alimentazione dell'apparecchio  
 Stromversorgung der Leuchte unterbrechen



Quitar la(s) fuente(s) de luz para el desecho  
 Remove light source(s) for disposal  
 Retirer la (les) source(s) lumineuse(s) pour l'élimination  
 Rimuovere la/le sorgente/e di luce per lo smaltimento  
 Lichtquelle(n) zur Entsorgung entfernen



Quitar la batería para el desecho  
 Remove the battery for decommissioning  
 Retirer la batterie pour sa mise au rebut  
 Rimuovere la batteria per la dismissione  
 Die Batterie ordnungsgemäß entsorgen



Quitar el equipo de control para el desecho  
 Remove control gear for disposal  
 Retirer le dispositif de commande pour l'élimination  
 Rimuovere l'alimentatore per lo smaltimento  
 Betriebsgerät zur Entsorgung ausbauen



Enviar los materiales a un centro de recogida RAEE  
 Send the materials to a WEEE collection centre  
 Envoyer les matériaux dans une déchetterie DEEE  
 Inviare i materiali ad un centro di raccolta RAEE  
 Die Materialien in einem WEEE-Zentrum entsorgen

